

BEACON DCB



DESCRIPTION

The Brilliance Beacon Double Contact Bayonet (DCB) is a subcompact LED that features Brilliance's omni-directional beam pattern. This DCB is energy efficient and water resistant. It is designed specifically for landscape retrofit applications and is ideal for pathway lighting fixtures, wall washing, and hanging fixtures. Dimmable with Brilliance Dimmer and most magnetic transformers. Suitable for damp locations and for use in totally enclosed luminaires. Not for underwater use.

BEACON DCB FEATURES

- Ceramic technology
- UL Certified E360351

BEACON DCB SPECS

Wattage	2W
Volt Amps	3.28
Lumens	2700K 200
	3000K 225
Beam Spread	Omni-directional
Kelvin Temperature	2700, 3000
Operating Range	8-25 VAC/DC
Replaces	20W Halogen
CRI	84
IP	65
Lamp Life (hours)	35,000
Warranty (years)	5

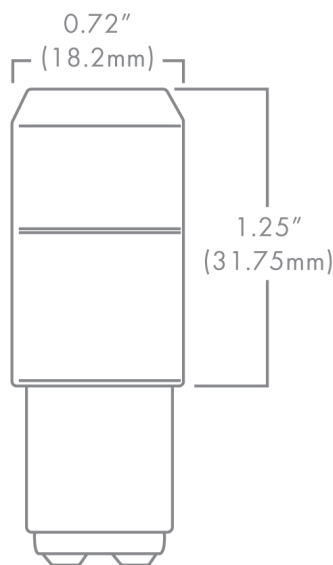

Part Number: **BRI-BEACON-DCB-XXXX**

↓
Kelvin

